

High performance curved jaw couplings

MIKI PULLEY STARFLEX



General-purpose Coupling of Simple Construction

Motive power is transmitted by polyurethane elastomer with the elastic force of rubber. These not only excel in absorbing vibration and shock, they transmit more than double the torque of older jaw couplings. The line-up includes three types of hubs, two types of elements and two types of fit. They can provide the optimum combination for your transmission torque, response, and misalignment. Since you can combine different hubs, they can be used in a wide range of applications.

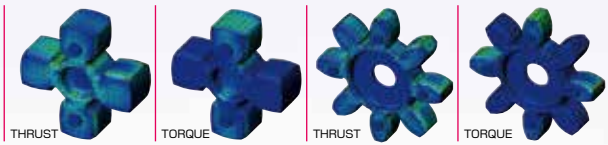

Reduced Counterforce

Optimal design of the element shape reduces mounting error counterforce to not damage the shaft. The R and Y types have no backlash and yet can absorb shock and vibration.

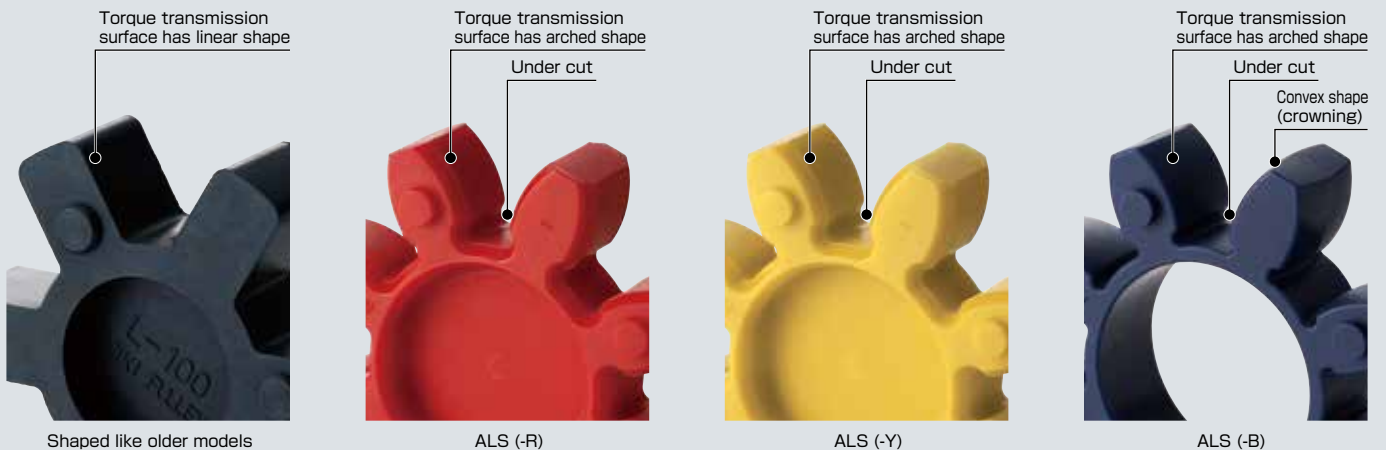

Three types of elements

There are three MIKI PULLEY STARFLEX models. Each has a different type of element.

ALS (-R) Type

- Shore hardness (Element) 97 JIS A
- Tight fit (precompressed construction)
- No-backlash
- High-torque, high-response models



ALS (-Y) Type

- Shore hardness (Element) 90 JIS A
- Tight fit (precompressed construction)
- No-backlash
- Good balance of torque transmission performance, flexibility, and responsiveness

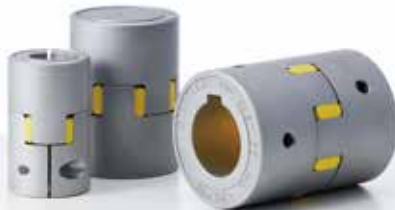

ALS (-B) Type

- Shore hardness (Element) 97 JIS A
- Loose fit
- High-torque, flexible models



Various Types of Combinations

The line-up includes three types of hubs: pilotbore products that allow free bore drilling, key / set screw types that enable high transmission torque, and clamp types that are easy to mount and remove.

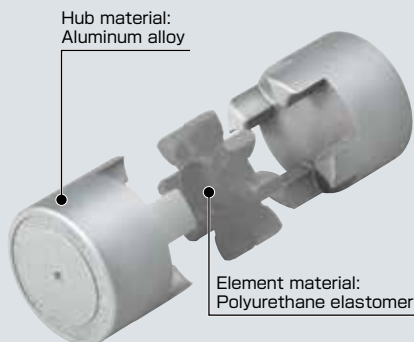

Pilot Bore

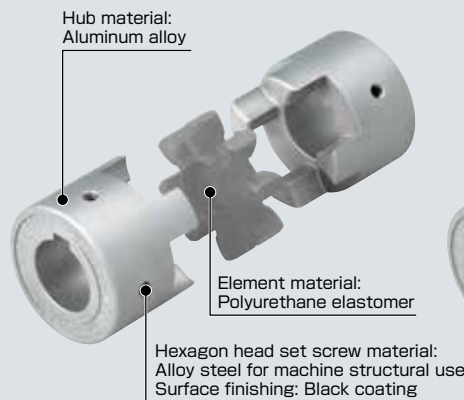

Key/Set Screw Type

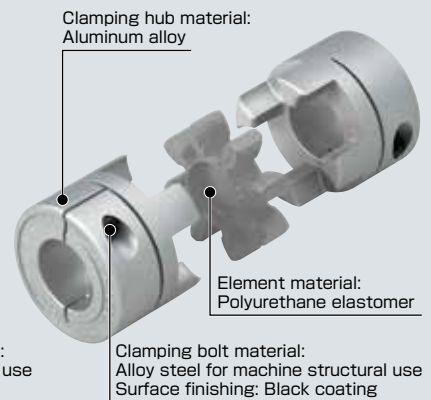

Clamp Type

ALS (-R) Type Key/Set Screw Type



Specifications

Model	Torque		Misalignment			Max. rotation speed [min ⁻¹]	Static torsional stiffness [N · m/rad]	Radial stiffness [N/mm]	Moment of inertia [kg · m ²]	Mass [kg]
	Nominal [N · m]	Max. [N · m]	Parallel [mm]	Angular [°]	Axial [mm]					
ALS-014-R	2	4	0.10	1	0~+0.6	34100	21	380	1.91 × 10 ⁻⁷	0.007
ALS-020-R	5	10	0.10	1	0~+0.8	23800	43	400	1.08 × 10 ⁻⁶	0.018
ALS-030-R	12.5	25	0.10	1	0~+1.0	15900	136	650	6.25 × 10 ⁻⁶	0.047
ALS-040-R	17	34	0.10	1	0~+1.2	11900	1550	1700	3.87 × 10 ⁻⁶	0.15
ALS-055-R	60	120	0.10	1	0~+1.4	8700	2000	1350	1.66 × 10 ⁻⁴	0.35
ALS-065-R	160	320	0.10	1	0~+1.5	7400	3100	1400	3.57 × 10 ⁻⁴	0.51
ALS-080-R	325	650	0.10	1	0~+1.8	6000	6000	1710	1.06 × 10 ⁻³	1.01
ALS-095-R	450	900	0.10	1	-0.5~+2.0	5000	10000	4200	2.24 × 10 ⁻³	1.50
ALS-105-R	525	1050	0.15	1	-0.9~+2.0	4500	12000	5000	3.72 × 10 ⁻³	2.05

* Axial displacement of the ALS-014-R to ALS-080-R is not allowed in the negative direction. * Max. rotation speed does not take into account dynamic balance. * Stiffness values given are from measurements taken at 20°C. * The moment of inertia and mass are measured for the maximum bore diameter.

Dimensions

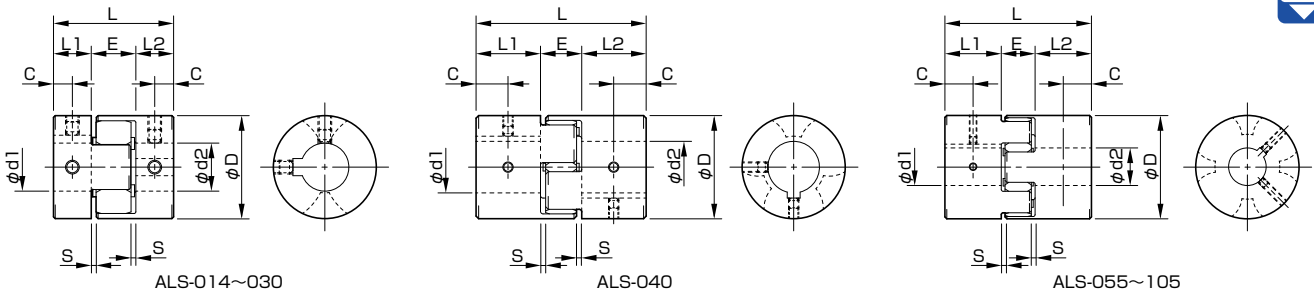

Model	d1 · d2			D [mm]	L [mm]	L1 · L2 [mm]	E [mm]	S [mm]	C [mm]
	Pilot bore [mm]	Min. [mm]	Max. [mm]						
ALS-014-R	3	3	6.5	14	22	7	8	1	3.5
ALS-020-R	4	4	9.6	20	30	10	10	1	5
ALS-030-R	5	6	14	30	35	11	13	1.5	5.5
ALS-040-R	5	8	22	40	66	25	16	2	12.5
ALS-055-R	5	10	28	55	78	30	18	2	15
ALS-065-R	5	14	38	65	90	35	20	2.5	17.5
ALS-080-R	10	19	45	80	114	45	24	3	22.5
ALS-095-R	8	19	55	95	126	50	26	3	25
ALS-105-R	10	19	60	105	140	56	28	3.5	28

* "Pilot bore" refers to center processing.

Standard Bore Diameter

Model	Standard bore diameter d1, d2 [mm]																														
	3	4	5	6	6.35	8	9	9.525	10	11	12	14	15	16	18	19	20	24	25	28	30	32	35	38	40	42	45	50	55	60	
ALS-014-R	●	●	●	●	●																										
ALS-020-R			●	●	●	●	●	●																							
ALS-030-R						●	●	●	●	●	●	●																			
ALS-040-R									●	●	●	●	●	●	●	●	●	●	●												
ALS-055-R													●	●	●	●	●	●	●	●	●	●	●	●	●	●	●	●	●	●	
ALS-065-R																		●	●	●	●	●	●	●	●	●	●	●	●	●	
ALS-080-R																					●	●	●	●	●	●	●	●	●	●	
ALS-095-R																										●	●	●	●	●	●
ALS-105-R																										●	●	●	●	●	●

* The bore diameters marked with ● are supported as standard bore diameter. * ø11 and below no keyway; ø12 and above can be processed for old JIS standards, new JIS standards, and new standard motors. * The only standard processing of bore diameters of the ALS-095 and ALS-105 are for new JIS standards and new standard motors.

How to Place an Order

ALS-055-R-24N-28H

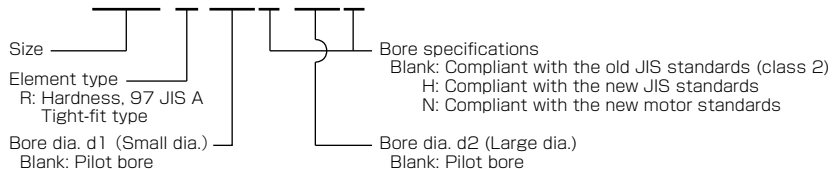

ALS (-R) Type Clamp Type



Specifications

Model	Torque		Misalignment			Max. rotation speed [min ⁻¹]	Static torsional stiffness [N · m/rad]	Radial stiffness [N/mm]	Moment of inertia [kg · m ²]	Mass [kg]
	Nominal [N · m]	Max. [N · m]	Parallel [mm]	Angular [°]	Axial [mm]					
ALS-014-R	(2)	(4)	0.10	1	0~+0.6	10000	21	380	1.98 × 10 ⁻⁷	0.007
ALS-020-R	(5)	(10)	0.10	1	0~+0.8	10000	43	400	1.09 × 10 ⁻⁶	0.019
ALS-030-R	(12.5)	(25)	0.10	1	0~+1.0	10000	136	650	6.19 × 10 ⁻⁶	0.045
ALS-040-R	(17)	(34)	0.10	1	0~+1.2	10000	1550	1700	4.01 × 10 ⁻⁵	0.16
ALS-055-R	(60)	(120)	0.10	1	0~+1.4	7000	2000	1350	1.63 × 10 ⁻⁴	0.34
ALS-065-R	(160)	(320)	0.10	1	0~+1.5	5900	3100	1400	3.69 × 10 ⁻⁴	0.54
ALS-080-R	(325)	(650)	0.10	1	0~+1.8	4800	6000	1710	1.04 × 10 ⁻³	1.00

* Check the Standard Bore Diameter and Rated Transmission Torque list as there may be limitations on the nominal and max. torque caused by the holding power of the coupling shaft section.
 * Axial displacement is not allowed in the negative direction. * Max. rotation speed does not take into account dynamic balance. * Stiffness values given are from measurements taken at 20°C.
 * The moment of inertia and mass are measured for the maximum bore diameter.

Dimensions

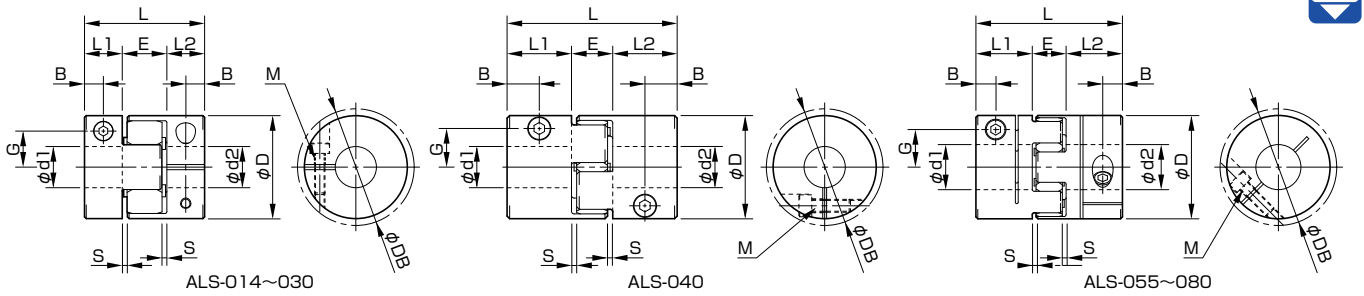

Model	d1 · d2		D [mm]	DB [mm]	L [mm]	L1 · L2 [mm]	E [mm]	S [mm]	B [mm]	G [mm]	M Quantity - Nominal dia.	Tightening torque [N · m]
	Min. [mm]	Max. [mm]										
ALS-014-R	3	6	14	16.1	22	7	8	1	3.5	4.8	1-M2	0.4
ALS-020-R	4	8	20	20	30	10	10	1	5	6.5	1-M2.5	1
ALS-030-R	6	14	30	30	35	11	13	1.5	5.5	10.5	1-M3	1.5
ALS-040-R	8	20	40	43.2	66	25	16	2	12.5	15	1-M5	7
ALS-055-R	10	28	55	55	78	30	18	2	10.5	20	1-M6	14
ALS-065-R	14	35	65	69.8	90	35	20	2.5	11.5	24.5	1-M8	30
ALS-080-R	19	45	80	80	114	45	24	3	11.5	30	1-M8	30

* The DB value is measured assuming that the head of the clamping bolt is larger than the external diameter of the hub. * The nominal diameter for the clamping bolt M is equal to the quantity - the nominal diameter of the screw threads, where the quantity is for a hub on one side.

Standard Bore Diameter and Rated Transmission Torque

Model	Standard bore diameter d1, d2 [mm] and rated transmission torque [N · m]																							
	3	4	5	6	6.35	7	8	10	11	12	14	15	16	18	19	20	22	24	25	28	30	35	42	
ALS-014-R	0.31	0.42	0.54	0.65																				
ALS-020-R		1.2	1.6	2.1	2.2	2.6	3.0																	
ALS-030-R				2.0	2.2		3.4	4.7	5.4	6.0	7.4													
ALS-040-R							8	16		23	31	34	34		34									
ALS-055-R												38	41	48	51		54	61	67	71	80			
ALS-065-R																	61	68	75	79	89	96	114	
ALS-080-R																					108	121	151	194

* Bore diameters whose fields contain numbers are supported as the standard bore diameters. * Bore diameters whose fields contain numbers are restricted in their rated transmission torque by the holding power of the shaft connection component. The numbers indicate the rated transmission torque value [N·m]. * The recommended processing tolerance for paired mounting shafts is the h7 class. However, for a shaft diameter of ø35, the tolerance is $\frac{0.009}{0.008}$. * Bore diameters between the minimum and maximums shown in the dimensions table are compatible, but bore diameters other than those shown in the above table require other arrangements. Contact Miki Pulley for details.

How to Place an Order

ALS-055-R-24B-28B

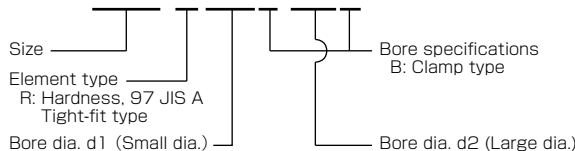

ALS (-Y) Type Key/Set Screw Type



Specifications

Model	Torque		Misalignment			Max. rotation speed [min ⁻¹]	Static torsional stiffness [N · m/rad]	Radial stiffness [N/mm]	Moment of inertia [kg · m ²]	Mass [kg]
	Nominal [N · m]	Max. [N · m]	Parallel [mm]	Angular [°]	Axial [mm]					
ALS-014-Y	1.2	2.4	0.10	1	0~+0.6	34100	12	200	1.91 × 10 ⁻⁷	0.007
ALS-020-Y	3	6	0.15	1	0~+0.8	23800	24	210	1.08 × 10 ⁻⁶	0.018
ALS-030-Y	7.5	15	0.15	1	0~+1.0	15900	73	330	6.25 × 10 ⁻⁶	0.047
ALS-040-Y	10	20	0.10	1	0~+1.2	11900	760	940	3.87 × 10 ⁻⁶	0.15
ALS-055-Y	35	70	0.15	1	0~+1.4	8700	1400	1160	1.66 × 10 ⁻⁴	0.35
ALS-065-Y	95	190	0.15	1	0~+1.5	7400	2100	1200	3.57 × 10 ⁻⁴	0.51
ALS-080-Y	190	380	0.15	1	0~+1.8	6000	4000	1430	1.06 × 10 ⁻³	1.01
ALS-095-Y	265	530	0.15	1	-0.5~+2.0	5000	6000	2400	2.24 × 10 ⁻³	1.50
ALS-105-Y	310	620	0.20	1	-0.9~+2.0	4500	7000	4000	3.72 × 10 ⁻³	2.05

* Axial displacement of the ALS-014-R to ALS-080-R is not allowed in the negative direction. * Max. rotation speed does not take into account dynamic balance. * Stiffness values given are from measurements taken at 20°C. * The moment of inertia and mass are measured for the maximum bore diameter.

Dimensions

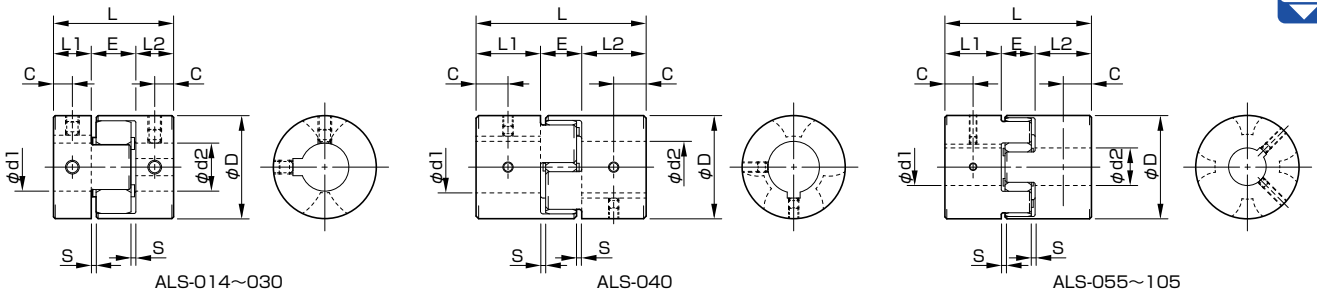

Model	d1 · d2			D [mm]	L [mm]	L1 · L2 [mm]	E [mm]	S [mm]	C [mm]
	Pilot bore [mm]	Min. [mm]	Max. [mm]						
ALS-014-Y	3	3	6.5	14	22	7	8	1	3.5
ALS-020-Y	4	4	9.6	20	30	10	10	1	5
ALS-030-Y	5	6	14	30	35	11	13	1.5	5.5
ALS-040-Y	5	8	22	40	66	25	16	2	12.5
ALS-055-Y	5	10	28	55	78	30	18	2	15
ALS-065-Y	5	14	38	65	90	35	20	2.5	17.5
ALS-080-Y	10	19	45	80	114	45	24	3	22.5
ALS-095-Y	8	19	55	95	126	50	26	3	25
ALS-105-Y	10	19	60	105	140	56	28	3.5	28

* "Pilot bore" refers to center processing.

Standard Bore Diameter

Model	Standard bore diameter d1, d2 [mm]																															
	3	4	5	6	6.35	8	9	9.525	10	11	12	14	15	16	18	19	20	24	25	28	30	32	35	38	40	42	45	50	55	60		
ALS-014-Y	●	●	●	●	●																											
ALS-020-Y			●	●	●	●	●	●																								
ALS-030-Y						●	●	●	●	●	●	●																				
ALS-040-Y									●	●	●	●	●	●	●	●	●	●	●													
ALS-055-Y													●	●	●	●	●	●	●	●	●	●	●	●	●	●	●	●	●	●		
ALS-065-Y																		●	●	●	●	●	●	●	●	●	●	●	●	●		
ALS-080-Y																					●	●	●	●	●	●	●	●	●	●	●	
ALS-095-Y																											●	●	●	●	●	●
ALS-105-Y																											●	●	●	●	●	●

* The bore diameters marked with ● are supported as standard bore diameter. * ø11 and below have no keyway; ø12 and above can be processed for old JIS standards, new JIS standards, and new standard motors. * The only standard processing of bore diameters of the ALS-095 and ALS-105 are for new JIS standards and new standard motors.

How to Place an Order

ALS-055-Y-24N-28H

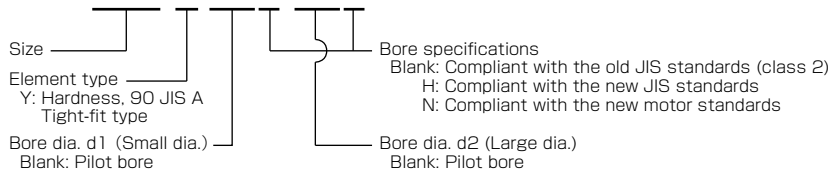

ALS (-Y) Type Clamp Type



Specifications

Model	Torque		Misalignment			Max. rotation speed [min ⁻¹]	Static torsional stiffness [N · m/rad]	Radial stiffness [N/mm]	Moment of inertia [kg · m ²]	Mass [kg]
	Nominal [N · m]	Max. [N · m]	Parallel [mm]	Angular [°]	Axial [mm]					
ALS-014-Y	(1.2)	(2.4)	0.10	1	0~+0.6	10000	12	200	1.98 × 10 ⁻⁷	0.007
ALS-020-Y	(3)	(6)	0.15	1	0~+0.8	10000	24	210	1.09 × 10 ⁻⁶	0.019
ALS-030-Y	(7.5)	(15)	0.15	1	0~+1.0	10000	73	330	6.19 × 10 ⁻⁶	0.045
ALS-040-Y	(10)	(20)	0.10	1	0~+1.2	10000	760	940	4.01 × 10 ⁻⁵	0.16
ALS-055-Y	(35)	(70)	0.15	1	0~+1.4	7000	1400	1160	1.63 × 10 ⁻⁴	0.34
ALS-065-Y	(95)	(190)	0.15	1	0~+1.5	5900	2100	1200	3.69 × 10 ⁻⁴	0.54
ALS-080-Y	(190)	(380)	0.15	1	0~+1.8	4800	4000	1430	1.04 × 10 ⁻³	1.00

* Check the Standard Bore Diameter and Rated Transmission Torque list as there may be limitations on the nominal and max. torque caused by the holding power of the coupling shaft section.
 * Axial displacement is not allowed in the negative direction. * Max. rotation speed does not take into account dynamic balance. * Stiffness values given are from measurements taken at 20C.
 * The moment of inertia and mass are measured for the maximum bore diameter.

Dimensions

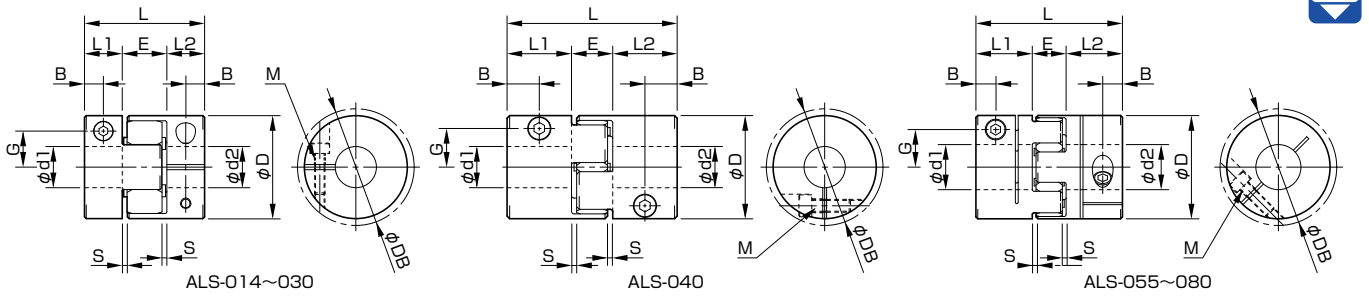

Model	d1 · d2		D [mm]	DB [mm]	L [mm]	L1 · L2 [mm]	E [mm]	S [mm]	B [mm]	G [mm]	M Quantity - Nominal dia.	Tightening torque [N · m]
	Min. [mm]	Max. [mm]										
ALS-014-Y	3	6	14	16.1	22	7	8	1	3.5	4.8	1-M2	0.4
ALS-020-Y	4	8	20	20	30	10	10	1	5	6.5	1-M2.5	1
ALS-030-Y	6	14	30	30	35	11	13	1.5	5.5	10.5	1-M3	1.5
ALS-040-Y	8	20	40	43.2	66	25	16	2	12.5	15	1-M5	7
ALS-055-Y	10	28	55	55	78	30	18	2	10.5	20	1-M6	14
ALS-065-Y	14	35	65	69.8	90	35	20	2.5	11.5	24.5	1-M8	30
ALS-080-Y	19	45	80	80	114	45	24	3	11.5	30	1-M8	30

* The DB value is measured assuming that the head of the clamping bolt is larger than the external diameter of the hub. * The nominal diameter for the clamping bolt M is equal to the quantity - the nominal diameter of the screw threads, where the quantity is for a hub on one side.

Standard Bore Diameter and Rated Transmission Torque

Model	Standard bore diameter d1, d2 [mm] and rated transmission torque [N · m]																							
	3	4	5	6	6.35	7	8	10	11	12	14	15	16	18	19	20	22	24	25	28	30	35	42	
ALS-014-Y	0.31	0.42	0.54	0.65																				
ALS-020-Y		1.2	1.6	2.1	2.2	2.6	3.0																	
ALS-030-Y				2.0	2.2		3.4	4.7	5.4	6.0	7.4													
ALS-040-Y							8	16		20	20	20	20											
ALS-055-Y												38	41	48	51	54	61	67	70	70				
ALS-065-Y																61	68	75	79	89	96	114		
ALS-080-Y																				108	121	151	194	

* Bore diameters whose fields contain numbers are supported as the standard bore diameters. * Bore diameters whose fields contain numbers are restricted in their rated transmission torque by the holding power of the shaft connection component. The numbers indicate the rated transmission torque value [N·m]. * The recommended processing tolerance for paired mounting shafts is the h7 class. However, for a shaft diameter of ø35, the tolerance is $\frac{0.009}{0.008}$. * Bore diameters between the minimum and maximums shown in the dimensions table are compatible, but bore diameters other than those shown in the above table require other arrangements. Contact Miki Pulley for details.

How to Place an Order

ALS-055-Y-24B-28B

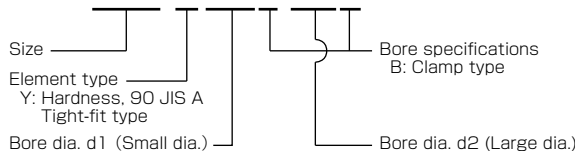

ALS (-B) Type Key/Set Screw Type



Specifications

Model	Torque		Misalignment			Max. rotation speed [min ⁻¹]	Static torsional stiffness [N · m/rad]	Radial stiffness [N/mm]	Moment of inertia [kg · m ²]	Mass [kg]
	Nominal [N · m]	Max. [N · m]	Parallel [mm]	Angular [°]	Axial [mm]					
ALS-030-B	12.5	25	0.17	1	-0.2 ~ +1.0	15900	90	460	6.13 × 10 ⁻⁶	0.045
ALS-040-B	17	34	0.20	1	-0.5 ~ +1.2	11900	400	640	3.86 × 10 ⁻⁵	0.15
ALS-055-B	60	120	0.22	1	-0.2 ~ +1.4	8700	1150	400	1.66 × 10 ⁻⁴	0.35
ALS-065-B	160	320	0.25	1	-0.6 ~ +1.5	7400	2000	800	3.57 × 10 ⁻⁴	0.51
ALS-080-B	325	650	0.28	1	-0.9 ~ +1.8	6000	4550	600	1.06 × 10 ⁻³	1.01
ALS-095-B	450	900	0.32	1	-0.5 ~ +2.0	5000	12000	800	2.22 × 10 ⁻³	1.48
ALS-105-B	525	1050	0.36	1	-0.9 ~ +2.0	4500	15000	2000	3.70 × 10 ⁻³	2.02

* Max. rotation speed does not take into account dynamic balance. * Stiffness values given are from measurements taken at 20°C. * The moment of inertia and mass are measured for the maximum bore diameter.

Dimensions

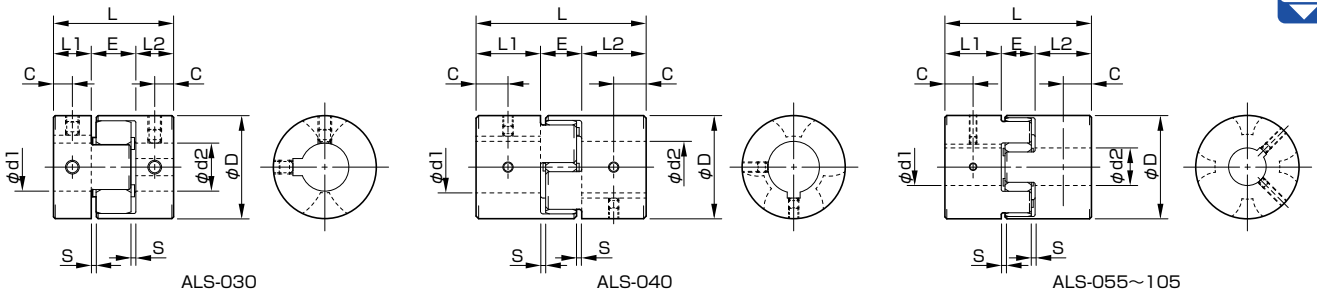

Model	d1 · d2			D [mm]	L [mm]	L1 · L2 [mm]	E [mm]	S [mm]	C [mm]
	Pilot bore [mm]	Min. [mm]	Max. [mm]						
ALS-030-B	5	6	14	30	35	11	13	1.5	5.5
ALS-040-B	5	8	22	40	66	25	16	2	12.5
ALS-055-B	5	10	28	55	78	30	18	2	15
ALS-065-B	5	14	38	65	90	35	20	2.5	17.5
ALS-080-B	10	19	45	80	114	45	24	3	22.5
ALS-095-B	8	19	55	95	126	50	26	3	25
ALS-105-B	10	19	60	105	140	56	28	3.5	28

* "Pilot bore" refers to center processing.

Standard Bore Diameter

Model	Standard bore diameter d1, d2 [mm]																								
	8	9	9.525	10	11	12	14	15	16	18	19	20	24	25	28	30	32	35	38	40	42	45	50	55	60
ALS-030-B	●	●	●	●	●	●	●																		
ALS-040-B					●	●	●	●	●	●	●	●													
ALS-055-B								●	●	●	●	●	●	●	●	●									
ALS-065-B												●	●	●	●	●	●								
ALS-080-B																●	●	●							
ALS-095-B																			●	●	●	●	●	●	●
ALS-105-B																				●	●	●	●	●	●

* The bore diameters marked with ● are supported as standard bore diameter. * ø11 and below have no keyway; ø12 and above can be processed for old JIS standards, new JIS standards, and new standard motors. * The only standard processing of bore diameters of the ALS-095 and ALS-105 are for new JIS standards and new standard motors.

How to Place an Order

ALS-055-B-24N-28H

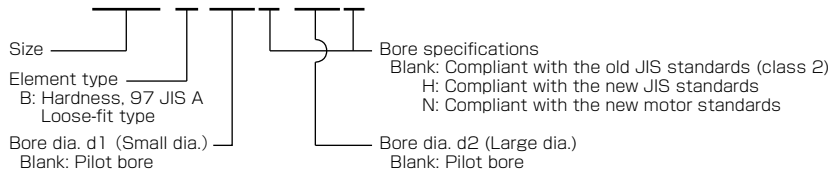

ALS (-B) Type Clamp Type



Specifications

Model	Torque		Misalignment			Max. rotation speed [min ⁻¹]	Static torsional stiffness [N · m/rad]	Radial stiffness [N/mm]	Moment of inertia [kg · m ²]	Mass [kg]
	Nominal [N · m]	Max. [N · m]	Parallel [mm]	Angular [°]	Axial [mm]					
ALS-030-B	(12.5)	(25)	0.17	1	-0.2 ~ +1.0	10000	90	460	6.07 × 10 ⁻⁶	0.043
ALS-040-B	(17)	(34)	0.20	1	-0.5 ~ +1.2	10000	400	640	4.00 × 10 ⁻⁵	0.16
ALS-055-B	(60)	(120)	0.22	1	-0.2 ~ +1.4	7000	1150	400	1.63 × 10 ⁻⁴	0.34
ALS-065-B	(160)	(320)	0.25	1	-0.6 ~ +1.5	5900	2000	800	3.69 × 10 ⁻⁴	0.54
ALS-080-B	(325)	(650)	0.28	1	-0.9 ~ +1.8	4800	4550	600	1.04 × 10 ⁻³	1.00

* Check the Standard Bore Diameter and Rated Transmission Torque list as there may be limitations on the nominal and max. torque caused by the holding power of the coupling shaft section.
 * Max. rotation speed does not take into account dynamic balance. * Stiffness values given are from measurements taken at 20°C. * The moment of inertia and mass are measured for the maximum bore diameter.

Dimensions

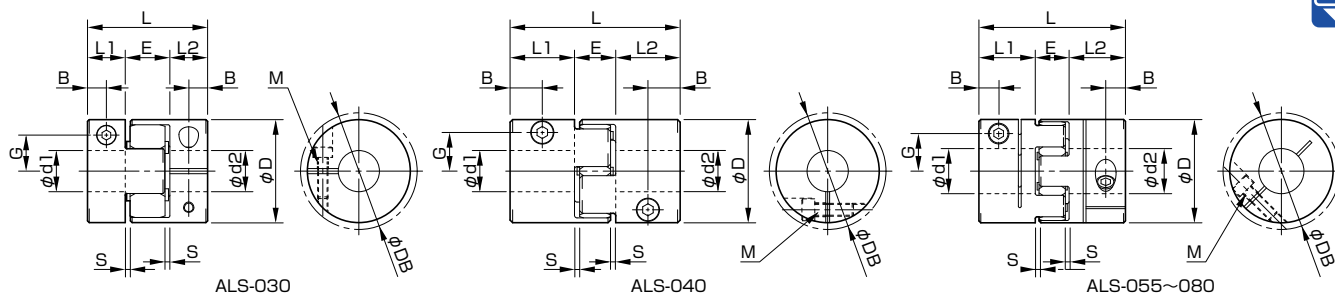

Model	d1 · d2		D [mm]	DB [mm]	L [mm]	L1 · L2 [mm]	E [mm]	S [mm]	B [mm]	G [mm]	M Quantity - Nominal dia.	Tightening torque [N · m]
	Min. [mm]	Max. [mm]										
ALS-030-B	6	14	30	30	35	11	13	1.5	5.5	10.5	1-M3	1.5
ALS-040-B	8	20	40	43.2	66	25	16	2	12.5	15	1-M5	7
ALS-055-B	10	28	55	55	78	30	18	2	10.5	20	1-M6	14
ALS-065-B	14	35	65	69.8	90	35	20	2.5	11.5	24.5	1-M8	30
ALS-080-B	19	45	80	80	114	45	24	3	11.5	30	1-M8	30

* The ϕDB value is measured assuming that the head of the clamping bolt is larger than the external diameter of the hub. * The nominal diameter for the clamping bolt M is equal to the quantity - the nominal diameter of the screw threads, where the quantity is for a hub on one side.

Standard Bore Diameter and Rated Transmission Torque

Model	Standard bore diameter d1, d2 [mm] and rated transmission torque [N · m]																		
	6	6.35	8	10	11	12	14	15	16	18	19	20	22	24	25	28	30	35	42
ALS-030-B	2.0	2.2	3.4	4.7	5.4	6.0	7.4												
ALS-040-B			8	16		23	31	34	34		34								
ALS-055-B								38	41	48	51	54	61	67	71	80			
ALS-065-B												61	68	75	79	89	96	114	
ALS-080-B																108	121	151	194

* Bore diameters whose fields contain numbers are supported as the standard bore diameters. * Bore diameters whose fields contain numbers are restricted in their rated transmission torque by the holding power of the shaft connection component. The numbers indicate the rated transmission torque value [N·m]. * The recommended processing tolerance for paired mounting shafts is the h7 class. However, for a shaft diameter of $\phi 35$, the tolerance is $\frac{+0.010}{-0.025}$. * Bore diameters between the minimum and maximums shown in the dimensions table are compatible, but bore diameters other than those shown in the above table require other arrangements. Contact Miki Pulley for details.

How to Place an Order

ALS-055-B-24B-28B

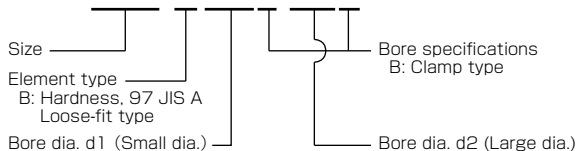

ALS MODEL Elements



■ Dimensions ALS(-R) • ALS(-Y)

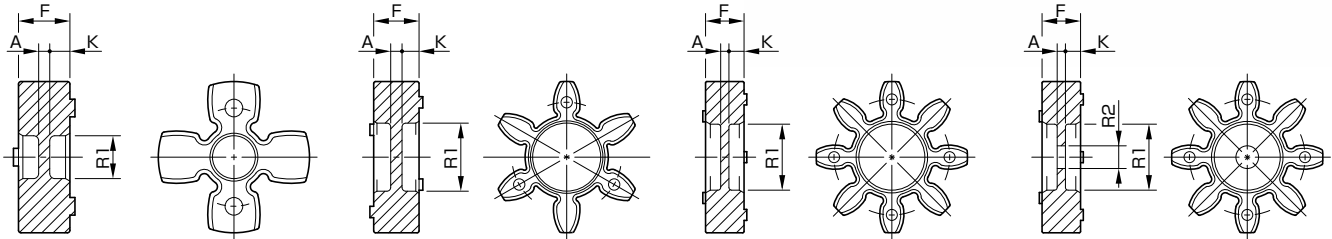

ALS-014 ~ 030-□-EL

ALS-040-□-EL

ALS-055 ~ 065-□-EL

ALS-080 ~ 105-□-EL

Model	F [mm]	R1 [mm]	R2 [mm]	K [mm]	A [mm]
ALS-014-□-EL	6.2	3.5	-	2.5	1.2
ALS-020-□-EL	8.2	6.2	-	3.4	1.4
ALS-030-□-EL	10.2	8.5	-	4	2.2
ALS-040-□-EL	12	18	-	4.5	3
ALS-055-□-EL	14	24	-	5.5	3
ALS-065-□-EL	15	30	-	5.5	4
ALS-080-□-EL	18	37	15	7	4
ALS-095-□-EL	20	43	20	8	4
ALS-105-□-EL	21	50	20	8.5	4

How to Place an Order

ALS-055-R-EL

Size ——— Element only
 Element type
 R: Hardness 97 JIS A; Tight-fit type
 Y: Hardness 90 JIS A; Tight-fit type

■ Dimensions ALS(-B)

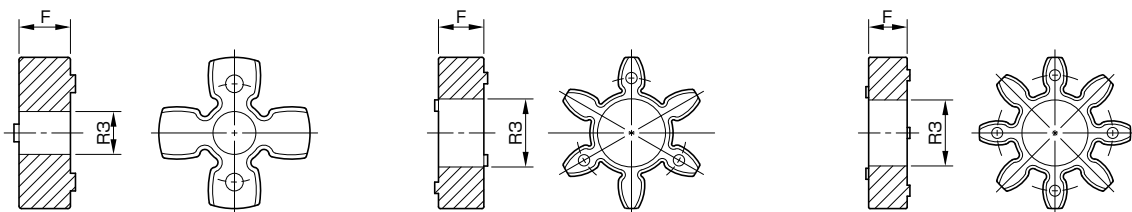

ALS-030-B-EL

ALS-040-B-EL

ALS-055 ~ 105-B-EL

Model	F [mm]	R3 [mm]
ALS-030-B-EL	10.2	10.5
ALS-040-B-EL	12	18.5
ALS-055-B-EL	14	27.5
ALS-065-B-EL	15	32
ALS-080-B-EL	18	41
ALS-095-B-EL	20	47
ALS-105-B-EL	21	50

How to Place an Order

ALS-055-B-EL

Size ——— Element only
 Element type
 B: Hardness 97 JIS A; Loose-fit type

Standard Hole-Drilling Standards

Hole-Drilling Standards

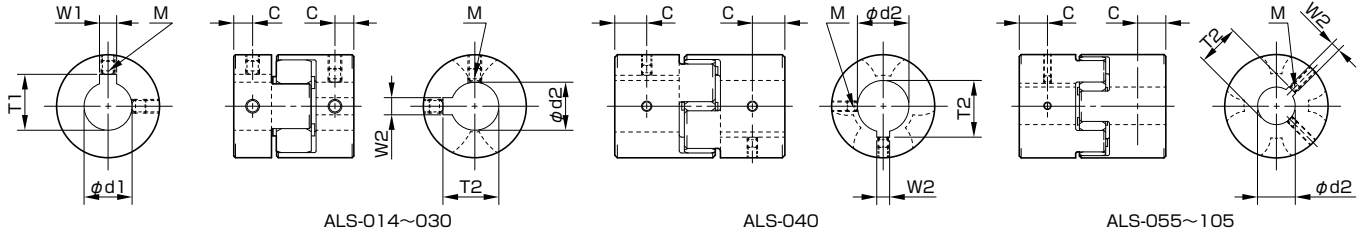

Models compliant with the old JIS standards (class 2)					Models compliant with the new JIS standards					Models compliant with the new motor standards				
Nominal bore dia.	Bore dia.	Key way width	Key way height	Set screw	Nominal bore dia.	Bore dia.	Key way width	Key way height	Set screw	Nominal bore dia.	Bore dia.	Key way width	Key way height	Set screw
	d1 · d2 [mm]	W1 · W2 [mm]	T1 · T2 [mm]			d1 · d2 [mm]	W1 · W2 [mm]	T1 · T2 [mm]			d1 · d2 [mm]	W1 · W2 [mm]	T1 · T2 [mm]	
	Tolerance H7,H8	Tolerance E9	Tolerance +0.3	M Quantity-Nominal dia.		Tolerance H7	Tolerance H9	Tolerance +0.3	M Quantity-Nominal dia.		Tolerance G7,F7	Tolerance H9	Tolerance +0.3	M Quantity-Nominal dia.
3	3 ^{+0.018} ₀	-	-	1-M3	-	-	-	-	-	-	-	-	-	-
4	4 ^{+0.018} ₀	-	-	2-M3	-	-	-	-	-	-	-	-	-	-
5	5 ^{+0.018} ₀	-	-	2-M3	-	-	-	-	-	-	-	-	-	-
6	6 ^{+0.018} ₀	-	-	2-M4	-	-	-	-	-	-	-	-	-	-
6.35	6.35 ^{+0.022} ₀	-	-	2-M4	-	-	-	-	-	-	-	-	-	-
7	7 ^{+0.022} ₀	-	-	2-M4	-	-	-	-	-	-	-	-	-	-
8	8 ^{+0.022} ₀	-	-	2-M4	-	-	-	-	-	-	-	-	-	-
9	9 ^{+0.022} ₀	-	-	2-M4	-	-	-	-	-	-	-	-	-	-
9.525	9.525 ^{+0.022} ₀	-	-	2-M4	-	-	-	-	-	-	-	-	-	-
10	10 ^{+0.022} ₀	-	-	2-M4	-	-	-	-	-	-	-	-	-	-
11	11 ^{+0.018} ₀	-	-	2-M4	-	-	-	-	-	-	-	-	-	-
12	12 ^{+0.018} ₀	4 ^{+0.050} ₀	13.5 ^{+0.3} ₀	2-M4	12H	12 ^{+0.018} ₀	4 ^{+0.030} ₀	13.8 ^{+0.3} ₀	2-M4	-	-	-	-	-
14	14 ^{+0.018} ₀	5 ^{+0.050} ₀	16.0 ^{+0.3} ₀	2-M4	14H	14 ^{+0.018} ₀	5 ^{+0.030} ₀	16.3 ^{+0.3} ₀	2-M4	14N	14 ^{+0.024} ₀	5 ^{+0.030} ₀	16.3 ^{+0.3} ₀	2-M4
15	15 ^{+0.018} ₀	5 ^{+0.050} ₀	17.0 ^{+0.3} ₀	2-M4	15H	15 ^{+0.018} ₀	5 ^{+0.030} ₀	17.3 ^{+0.3} ₀	2-M4	-	-	-	-	-
16	16 ^{+0.018} ₀	5 ^{+0.050} ₀	18.0 ^{+0.3} ₀	2-M4	16H	16 ^{+0.018} ₀	5 ^{+0.030} ₀	18.3 ^{+0.3} ₀	2-M4	-	-	-	-	-
17	17 ^{+0.018} ₀	5 ^{+0.050} ₀	19.0 ^{+0.3} ₀	2-M4	17H	17 ^{+0.018} ₀	5 ^{+0.030} ₀	19.3 ^{+0.3} ₀	2-M4	-	-	-	-	-
18	18 ^{+0.018} ₀	5 ^{+0.050} ₀	20.0 ^{+0.3} ₀	2-M4	18H	18 ^{+0.018} ₀	6 ^{+0.030} ₀	20.8 ^{+0.3} ₀	2-M5	-	-	-	-	-
19	19 ^{+0.021} ₀	5 ^{+0.050} ₀	21.0 ^{+0.3} ₀	2-M4	19H	19 ^{+0.021} ₀	6 ^{+0.030} ₀	21.8 ^{+0.3} ₀	2-M5	19N	19 ^{+0.028} ₀	6 ^{+0.030} ₀	21.8 ^{+0.3} ₀	2-M5
20	20 ^{+0.021} ₀	5 ^{+0.050} ₀	22.0 ^{+0.3} ₀	2-M4	20H	20 ^{+0.021} ₀	6 ^{+0.030} ₀	22.8 ^{+0.3} ₀	2-M5	-	-	-	-	-
22	22 ^{+0.021} ₀	7 ^{+0.061} ₀	25.0 ^{+0.3} ₀	2-M6	22H	22 ^{+0.021} ₀	6 ^{+0.030} ₀	24.8 ^{+0.3} ₀	2-M5	-	-	-	-	-
24	24 ^{+0.021} ₀	7 ^{+0.061} ₀	27.0 ^{+0.3} ₀	2-M6	24H	24 ^{+0.021} ₀	8 ^{+0.036} ₀	27.3 ^{+0.3} ₀	2-M6	24N	24 ^{+0.028} ₀	8 ^{+0.036} ₀	27.3 ^{+0.3} ₀	2-M6
25	25 ^{+0.021} ₀	7 ^{+0.061} ₀	28.0 ^{+0.3} ₀	2-M6	25H	25 ^{+0.021} ₀	8 ^{+0.036} ₀	28.3 ^{+0.3} ₀	2-M6	-	-	-	-	-
28	28 ^{+0.021} ₀	7 ^{+0.061} ₀	31.0 ^{+0.3} ₀	2-M6	28H	28 ^{+0.021} ₀	8 ^{+0.036} ₀	31.3 ^{+0.3} ₀	2-M6	28N	28 ^{+0.028} ₀	8 ^{+0.036} ₀	31.3 ^{+0.3} ₀	2-M6
30	30 ^{+0.021} ₀	7 ^{+0.061} ₀	33.0 ^{+0.3} ₀	2-M6	30H	30 ^{+0.021} ₀	8 ^{+0.036} ₀	33.3 ^{+0.3} ₀	2-M6	-	-	-	-	-
32	32 ^{+0.025} ₀	10 ^{+0.061} ₀	35.5 ^{+0.3} ₀	2-M8	32H	32 ^{+0.025} ₀	10 ^{+0.036} ₀	35.3 ^{+0.3} ₀	2-M8	-	-	-	-	-
35	35 ^{+0.025} ₀	10 ^{+0.061} ₀	38.5 ^{+0.3} ₀	2-M8	35H	35 ^{+0.025} ₀	10 ^{+0.036} ₀	38.3 ^{+0.3} ₀	2-M8	-	-	-	-	-
38	38 ^{+0.025} ₀	10 ^{+0.061} ₀	41.5 ^{+0.3} ₀	2-M8	38H	38 ^{+0.025} ₀	10 ^{+0.036} ₀	41.3 ^{+0.3} ₀	2-M8	38N	38 ^{+0.050} ₀	10 ^{+0.036} ₀	41.3 ^{+0.3} ₀	2-M8
40	40 ^{+0.025} ₀	10 ^{+0.061} ₀	43.5 ^{+0.3} ₀	2-M8	40H	40 ^{+0.025} ₀	12 ^{+0.043} ₀	43.3 ^{+0.3} ₀	2-M8	-	-	-	-	-
42	42 ^{+0.025} ₀	12 ^{+0.075} ₀	45.5 ^{+0.3} ₀	2-M8	42H	42 ^{+0.025} ₀	12 ^{+0.043} ₀	45.3 ^{+0.3} ₀	2-M8	42N	42 ^{+0.050} ₀	12 ^{+0.043} ₀	45.3 ^{+0.3} ₀	2-M8
45	45 ^{+0.025} ₀	12 ^{+0.075} ₀	48.5 ^{+0.3} ₀	2-M8	45H	45 ^{+0.025} ₀	14 ^{+0.043} ₀	48.8 ^{+0.3} ₀	2-M10	-	-	-	-	-
48	48 ^{+0.025} ₀	12 ^{+0.075} ₀	51.5 ^{+0.3} ₀	2-M8	48H	48 ^{+0.025} ₀	14 ^{+0.043} ₀	51.8 ^{+0.3} ₀	2-M10	48N	48 ^{+0.050} ₀	14 ^{+0.043} ₀	51.8 ^{+0.3} ₀	2-M10
50	50 ^{+0.025} ₀	12 ^{+0.075} ₀	53.5 ^{+0.3} ₀	2-M8	50H	50 ^{+0.025} ₀	14 ^{+0.043} ₀	53.8 ^{+0.3} ₀	2-M10	-	-	-	-	-
55	55 ^{+0.030} ₀	15 ^{+0.075} ₀	60.0 ^{+0.3} ₀	2-M10	55H	55 ^{+0.030} ₀	16 ^{+0.043} ₀	59.3 ^{+0.3} ₀	2-M10	55N	55 ^{+0.060} ₀	16 ^{+0.043} ₀	59.3 ^{+0.3} ₀	2-M10
56	56 ^{+0.030} ₀	15 ^{+0.075} ₀	61.0 ^{+0.3} ₀	2-M10	56H	56 ^{+0.030} ₀	16 ^{+0.043} ₀	60.3 ^{+0.3} ₀	2-M10	-	-	-	-	-
60	60 ^{+0.030} ₀	15 ^{+0.075} ₀	65.0 ^{+0.3} ₀	2-M10	60H	60 ^{+0.030} ₀	18 ^{+0.043} ₀	64.4 ^{+0.3} ₀	2-M10	60N	60 ^{+0.060} ₀	18 ^{+0.043} ₀	64.4 ^{+0.3} ₀	2-M10

Position of Set Screw

Model	Distance from end surface of the hub C [mm]
ALS-014	3.5
ALS-020	5
ALS-030	5.5
ALS-040	12.5
ALS-055	15
ALS-065	17.5
ALS-080	22.5
ALS-095	25
ALS-105	28

Note

- (1) Tolerance will be h8 class for hole diameter equal to or less than ø10 mm.
- (2) The set screw size is M3 for ALS-014.
- (3) Set screw and keyway positions are not on the same plane. Positioning precision for keyway milling is determined by sight, so contact Miki Pulley when the keyway requires a positioning precision for a particular hub.
- (4) The set screws are included with the product.
- (5) We also process non-standard bore diameters to the standards of the table below.
- (6) Contact Miki Pulley if you require standards other than those shown below.

Related Product

■ Tapered coupling type

The amount of thrust applied to the axis can be increased with the tapered shaft installation method.

- Adaptation size : 055 to 065
- Hub material : Aluminum alloy
- Element type : R : Red (Hardness 97 JIS A tight fit)



■ High-speed rotation specifications

These are high-speed rotation specifications for main spindles of machine tools. These hubs are processed with high precision to ensure high concentricity; they reduce imbalances and suppress vibration.

- Adaptation size : 065 to 080
- Hub material : Steel
- Element type : G : Green (Hardness 63D tight fit)



■ All processing type

Hubs are processed with high precision to ensure high concentricity; they reduce imbalances.

- Adaptation size : 014 to 105
- Hub material : Aluminum alloy
- Element type : R : Red / Y : Yellow / B : Blue



Items Checked for Design Purposes

■ Precautions for Handling

ALS models come with three different types of elements and two different types of mounting hubs. Be aware in their handling that their allowable values and points of caution are not the same.

- (1) Couplings are designed for use within an operating temperature range of -30°C to 80°C .
- (2) Although elements are designed to be oilproof, do not subject them to excessive amounts of oil as it may cause deterioration. Use and storage in direct sunlight may shorten element service life, so cover elements appropriately.
- (3) Do not tighten up clamping bolts on clamp-type ALS models until after inserting the mounting shaft.

■ Mounting

- (1) Remove any rust, dust, oil or the like from the inner diameter surfaces of the shaft and coupling. Be particularly careful to degrease or otherwise process clamp-type couplings (which use friction to hold shafts in place) to fully remove any grease, oil, or the like that is molybdenum disulfide based or contains extreme pressure additives that strongly affect coefficients of friction.
- (2) Insert each shaft far enough so that the paired mounting shaft touches the shaft along the entire length of the hub of the coupling ($L1/L2$ in dimensions table). After mounting the left and right hubs, check also that the total coupling length (L in the dimensions chart) does not exceed the permitted axial tolerance. If the total coupling length cannot be checked, use a feeler gauge or similar tool to check that the gap between the left and right hubs (S in the dimensions chart) does not exceed the permitted axial tolerance.

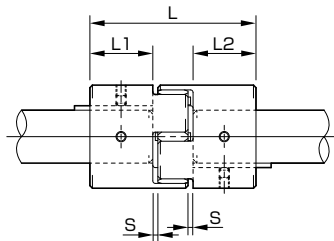

Model	L [mm]	L1 · L2 [mm]	S [mm]
ALS-014	22	7	1
ALS-020	30	10	1
ALS-030	35	11	1.5
ALS-040	66	25	2
ALS-055	78	30	2
ALS-065	90	35	2.5
ALS-080	114	45	3
ALS-095	126	50	3
ALS-105	140	56	3.5

- (3) To get full coupling performance, mount couplings so that differences between coupling centers during operation are within the misalignment shown in the specifications table. However, this misalignment is the maximum value when each occurs independently, so make the allowable value when they combine 50% or less of this value.
- (4) Check centering by holding a straight-edge to the outer circumference of the main body, using two points about 90° apart. The centering precision has a major impact on the service life of the element. We recommend aligning the centering locations as the method for centering the two shafts.

■ Misalignment

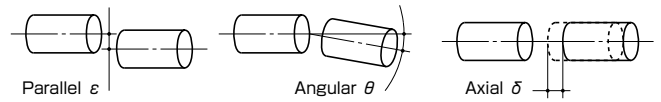

Model	Parallel ϵ [mm]	Angular θ [mm]	Axial δ [mm]	Axial (total length) L [mm]
ALS-014-R	0.10	1	0 ~ +0.6	22 ~ 22.6
ALS-020-R	0.10	1	0 ~ +0.8	30 ~ 30.8
ALS-030-R	0.10	1	0 ~ +1.0	35 ~ 36.0
ALS-040-R	0.10	1	0 ~ +1.2	66 ~ 67.2
ALS-055-R	0.10	1	0 ~ +1.4	78 ~ 79.4
ALS-065-R	0.10	1	0 ~ +1.5	90 ~ 91.5
ALS-080-R	0.10	1	0 ~ +1.8	114 ~ 115.8
ALS-095-R	0.10	1	-0.5 ~ +2.0	125.5 ~ 128.0
ALS-105-R	0.15	1	-0.9 ~ +2.0	139.1 ~ 142.0

Model	Parallel ϵ [mm]	Angular θ [mm]	Axial δ [mm]	Axial (total length) L [mm]
ALS-014-Y	0.10	1	0 ~ +0.6	22 ~ 22.6
ALS-020-Y	0.15	1	0 ~ +0.8	30 ~ 30.8
ALS-030-Y	0.15	1	0 ~ +1.0	35 ~ 36.0
ALS-040-Y	0.10	1	0 ~ +1.2	66 ~ 67.2
ALS-055-Y	0.15	1	0 ~ +1.4	78 ~ 79.4
ALS-065-Y	0.15	1	0 ~ +1.5	90 ~ 91.5
ALS-080-Y	0.15	1	0 ~ +1.8	114 ~ 115.8
ALS-095-Y	0.15	1	-0.5 ~ +2.0	125.5 ~ 128.0
ALS-105-Y	0.20	1	-0.9 ~ +2.0	139.1 ~ 142.0

Model	Parallel ϵ [mm]	Angular θ [mm]	Axial δ [mm]	Axial (total length) L [mm]
ALS-030-B	0.17	1	-0.2 ~ +1.0	34.8 ~ 36.0
ALS-040-B	0.20	1	-0.5 ~ +1.2	65.5 ~ 67.2
ALS-055-B	0.22	1	-0.2 ~ +1.4	77.8 ~ 79.4
ALS-065-B	0.25	1	-0.6 ~ +1.5	89.4 ~ 91.5
ALS-080-B	0.28	1	-0.9 ~ +1.8	113.1 ~ 115.8
ALS-095-B	0.32	1	-0.5 ~ +2.0	125.5 ~ 128.0
ALS-105-B	0.36	1	-0.9 ~ +2.0	139.1 ~ 142.0

- (5) Tighten set screws with hex socket heads and clamping bolts to the tightening torques shown below using a calibrated torque screwdriver or torque wrench.

Size of hex-socket-head set screw	M3	M4	M5	M6	M8	M10
Tightening torque [N · m]	0.7	1.7	3.6	6.0	14.5	28.0

Clamping bolt size	M2	M2.5	M3	M5	M6	M8
Tightening torque [N · m]	0.4	1.0	1.5	7.0	14.0	30.0

- (6) Do not use any hex-socket-head set screw or clamping bolt other than those specified by Miki Pulley. Do not apply oil, grease, or screw fixatives.

Items Checked for Design Purposes

■ Selection Procedures

ALS models can be selected in one of two ways depending on their mode of use: ordinary use or no-backlash use (exploiting their pre-compressed construction). When considering use of couplings in no-backlash mode, however, be sure that use will be at a torque that is low enough for the nominal torque of the coupling.

■ Ordinary use

- (1) Find the torque, T_a , applied to the coupling using the output capacity, P , of the driver and the usage rotation speed, n .

$$T_a \text{ [N}\cdot\text{m]} = 9550 \times \frac{P \text{ [kW]}}{n \text{ [min}^{-1}\text{]}}$$

- (2) Determine the service factor K from the usage and operating conditions, and find the corrected torque, T_d , applied to the coupling.

$$T_d \text{ [N}\cdot\text{m]} = T_a \text{ [N}\cdot\text{m]} \times K1 \times K2 \times K3 \times K4$$

■ Service factor based on load property : K1

Load properties	Constant	Vibration : Small	Vibration : Medium	Vibration : Large
K1	1.0	1.25	1.75	2.25

■ Service factor based on operating time : K2

Hrs./day	~8	~16	~24
K2	1.0	1.12	1.25

■ Service factor based on starting/braking frequency : K3

Times/hr.	~10	~30	~60	~120	~240	Over 240
K3	1.0	1.1	1.3	1.5	2.0	2.5 \leq

■ Service factor based on operating temperature : K4

Temperature [°C]	-30~30	30~40	40~60	60~80
K4	1.0	1.2	1.4	1.8

- (3) Set the size so that the nominal torque of the coupling T_n is at least equal to the corrected torque, T_d .

$$T_n \text{ [N}\cdot\text{m]} \geq T_d \text{ [N}\cdot\text{m]}$$

- (4) Select a size that results in a maximum torque, T_m , for the coupling that is at least equal to the peak torque, T_s , generated by the driver, follower or both. Maximum torque refers to the maximum amount of torque that can be applied for a set amount of time considering eight hours of operation per day and up to around ten instances.

$$T_m \text{ [N}\cdot\text{m]} \geq T_s \text{ [N}\cdot\text{m]} \times K4$$

- (5) When the required shaft diameter exceeds the maximum bore diameter of the selected size, select a suitable coupling.

- (6) When the coupling is used in machinery prone to periodic violent load-torque fluctuations, torsional vibration must also be considered in addition to the above selection criteria. In other words, check that the vibration frequency of the torque fluctuation does not match the natural frequency of the shafting. The natural frequency is generally calculated by finding the natural frequency, f_e , of one section, approximating the shafting as shown in the diagram below.

$$f_e = \frac{1}{2\pi} \sqrt{K \left(\frac{1}{J_A} + \frac{1}{J_B} \right)} \text{ [Hz]}$$

K : Static torsional stiffness of coupling [N · m/rad]
 J_1 : Moment of inertia of driving side [kg · m²]
 J_2 : Moment of inertia of driven side [kg · m²]

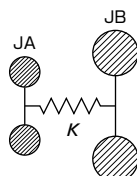

Note that selection criteria are different for ordinary use and use in no-backlash mode.

When considering use of couplings in no-backlash mode, select from among the ALS (-R) and ALS (-Y) types. ALS (-B) types cannot be used in no-backlash mode.

■ No-backlash use

- (1) Find the torque, T_a , applied to the coupling using the output capacity, P , of the driver and the usage rotation speed, n .

$$T_a \text{ [N}\cdot\text{m]} = 9550 \times \frac{P \text{ [kW]}}{n \text{ [min}^{-1}\text{]}}$$

- (2) Determine the service factor K from the usage and operating conditions, and find the corrected torque, T_d , applied to the coupling.

$$T_d \text{ [N}\cdot\text{m]} = T_a \text{ [N}\cdot\text{m]} \times K1 \times K2 \times K3 \times K4$$

■ Service factor based on load property : K1

Load properties	Constant	Vibration : Small	Vibration : Medium	Vibration : Large
K1	1.0	1.25	1.75	2.25

* When using in no-backlash mode, be sure that $K1 \geq 4$.

■ Service factor based on operating time : K2

Hrs./day	~8	~16	~24
K2	1.0	1.12	1.25

■ Service factor based on starting/braking frequency : K3

Times/hr.	~10	~30	~60	~120	~240	Over 240
K3	1.0	1.1	1.3	1.5	2.0	2.5 \leq

■ Service factor based on operating temperature : K4

Temperature [°C]	-30~30	30~40	40~60	60~80
K4	1.0	1.2	1.4	1.8

- (3) Select a size that results in a peak torque T_s generated by the driver, follower or both that is no greater than the nominal torque T_n for the coupling.

$$T_n \text{ [N}\cdot\text{m]} \geq T_s \text{ [N}\cdot\text{m]} \times K4$$

- (4) When the required shaft diameter exceeds the maximum bore diameter of the selected size, select a suitable coupling. When using a clamping hub, the bore diameter may restrict the transmission torque. For that reason, check that the clamping-hub shaft holding force of the selected coupling size is at least equal to the peak torque, T_s , applied to the coupling.

Couplings can structurally be used in no-backlash mode while the element is pre-compressed, but backlash may start to occur with use. If you are considering using the coupling in no-backlash mode over a long period of time, we recommend setting the service factor $K1$ to a high value.

If you require higher precision control/positioning for a long period of time, we recommend our SERVOFLEX series of metal disc couplings.

■ Induction Motor Specifications and Easy Selection Table

Motor		50Hz : 3000min ⁻¹ / 60Hz : 3600min ⁻¹				50Hz : 1500min ⁻¹ / 60Hz : 1800min ⁻¹				50Hz : 1000min ⁻¹ / 60Hz : 1200min ⁻¹			
		Two-pole motor		MIKI PULLEY STARFLEX		Four-pole motor		MIKI PULLEY STARFLEX		Six-pole motor		MIKI PULLEY STARFLEX	
Output [kW]	Frequency [Hz]	Shaft dia. [mm]	Torque [N·m]	Model	Nominal bore dia.	Shaft dia. [mm]	Torque [N·m]	Model	Nominal bore dia.	Shaft dia. [mm]	Torque [N·m]	Model	Nominal bore dia.
0.1	50	-	-	-	-	11	0.7	ALS-030	11	-	-	-	-
	60	-	-	-	-	11	0.5	ALS-030	11	-	-	-	-
0.2	50	11	0.7	ALS-030	11	11	1.3	ALS-030	11	-	-	-	-
	60	11	0.5	ALS-030	11	11	1.1	ALS-030	11	-	-	-	-
0.4	50	14	1.3	ALS-030	14N	14	2.6	ALS-030	14N	19	3.9	ALS-040	19N
	60	14	1.1	ALS-030	14N	14	2.2	ALS-030	14N	19	3.2	ALS-040	19N
0.75	50	19	2.4	ALS-040	19N	19	4.9	ALS-040	19N	24	7.3	ALS-055	24N
	60	19	2	ALS-040	19N	19	4.1	ALS-040	19N	24	6.1	ALS-055	24N
1.5	50	24	4.9	ALS-055	24N	24	9.7	ALS-055	24N	28	15	ALS-055	28N
	60	24	4.1	ALS-055	24N	24	8.1	ALS-055	24N	28	12	ALS-055	28N
2.2	50	24	7.1	ALS-055	24N	28	14	ALS-055	28N	28	21	ALS-065	28N
	60	24	6	ALS-055	24N	28	12	ALS-055	28N	28	18	ALS-065	28N
3.7	50	28	12	ALS-055	28N	28	24	ALS-065	28N	38	36	ALS-065	38N
	60	28	10	ALS-055	28N	28	20	ALS-065	28N	38	30	ALS-065	38N
5.5	50	38	18	ALS-065	38N	38	36	ALS-065	38N	38	54	ALS-080	38N
	60	38	15	ALS-065	38N	38	30	ALS-065	38N	38	45	ALS-065	38N
7.5	50	38	24	ALS-065	38N	38	49	ALS-065	38N	42	72	ALS-080	42N
	60	38	20	ALS-065	38N	38	41	ALS-065	38N	42	60	ALS-080	42N
11	50	42	36	ALS-080	42N	42	71	ALS-080	42N	42	108	ALS-080-R	42N
	60	42	30	ALS-080	42N	42	59	ALS-080	42N	42	90	ALS-080	42N
15	50	42	49	ALS-080	42N	42	97	ALS-080	42N	48	149	ALS-095-R	48N
	60	42	41	ALS-080	42N	42	81	ALS-080	42N	48	124	ALS-095	48N
18.5	50	42	65	ALS-080	42N	48	120	ALS-095	48N	55	183	ALS-095-R	55N
	60	42	50	ALS-080	42N	48	100	ALS-095	48N	55	152	ALS-095-R	55N
22	50	48	71	ALS-095	48N	48	143	ALS-095-R	48N	55	218	ALS-095-R	55N
	60	48	59	ALS-095	48N	48	119	ALS-095	48N	55	182	ALS-095-R	55N
30	50	55	97	ALS-095	55N	55	195	ALS-095-R	55N	60	296	-	60N
	60	55	81	ALS-095	55N	55	162	ALS-095-R	55N	60	247	ALS-105-R	60N
37	50	55	120	ALS-095	55N	60	240	ALS-105-R	60N	-	-	-	-
	60	55	100	ALS-095	55N	60	200	ALS-105-R	60N	-	-	-	-
45	50	55	146	ALS-105	55N	60	292	-	60N	-	-	-	-
	60	55	122	ALS-095	55N	60	243	ALS-105-R	60N	-	-	-	-

* The above table shows appropriate sizes for key types in ordinary use in an induction motor driver. It is not for making selections for use with no-backlash specifications.

* Motor rotation speed and output torque are calculated (reference) values.

■ Servo Motor Specifications and Easy Selection Table

Servo motor specifications					MIKI PULLEY STARFLEX specifications	
Rated output [kW]	Rated rotation speed [min ⁻¹]	Rated torque [N·m]	Max. torque [N·m]	Shaft dia. [mm]	Model ALS-□-R	Max. bore dia. [mm]
0.05	3000	0.16	0.48	8	ALS-020-R	8
0.1	3000	0.32	0.95	8	ALS-020-R	8
0.2	3000	0.64	1.9	14	ALS-030-R	14
0.4	3000	1.30	3.8	14	ALS-030-R	14
0.5	2000	2.39	7.16	24	ALS-055-R	28
0.5	3000	1.59	4.77	24	ALS-055-R	28
0.75	2000	3.58	10.7	22	ALS-055-R	28
0.75	3000	2.40	7.2	19	ALS-040-R	20
0.85	1000	8.12	24.4	24	ALS-055-R	28
1	2000	4.78	14.4	24	ALS-055-R	28
1	3000	3.18	9.55	24	ALS-055-R	28
1.2	1000	11.50	34.4	35	ALS-065-R	35
1.5	2000	7.16	21.6	28	ALS-055-R	28
1.5	3000	4.78	14.3	24	ALS-055-R	28
2	2000	9.55	28.5	35	ALS-065-R	35
2	3000	6.37	15.9	24	ALS-055-R	28
3	1000	28.60	85.9	35	ALS-065-R	35
3.5	2000	16.70	50.1	35	ALS-065-R	35
3.5	3000	11.10	27.9	28	ALS-055-R	28
5	2000	23.90	71.6	35	ALS-065-R	35
5	3000	15.90	39.7	28	ALS-055-R	28
7	2000	33.40	100	35	ALS-065-R	35

* The above table was set up in simple terms for clamp types based on the shaft diameters of compatible servo motors and the rated transmission torque of the coupling. It is not guaranteed when using the couplings in the no-backlash mode.

